

SAFE

RIVERINE PATROL BOAT

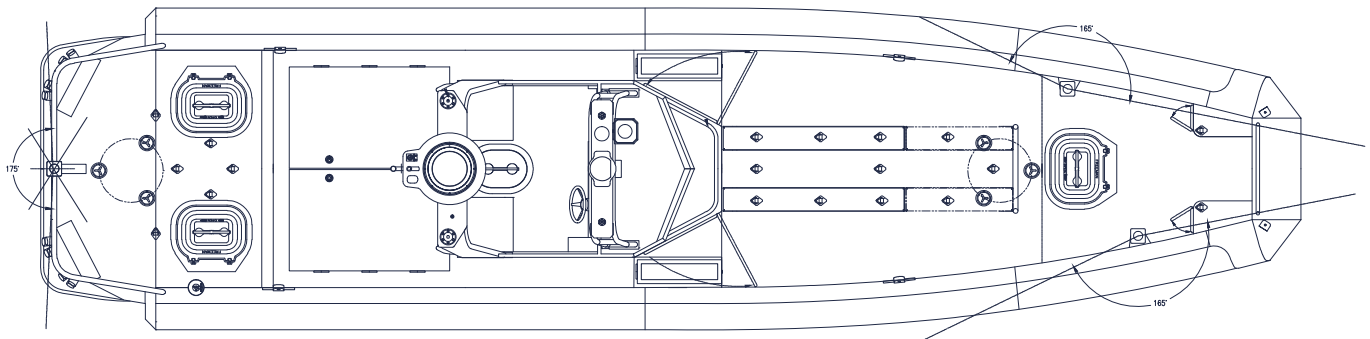

**SAFE RIVERINE PATROL BOAT**  
**VISUAL REFERENCE + SPECIFICATIONS**

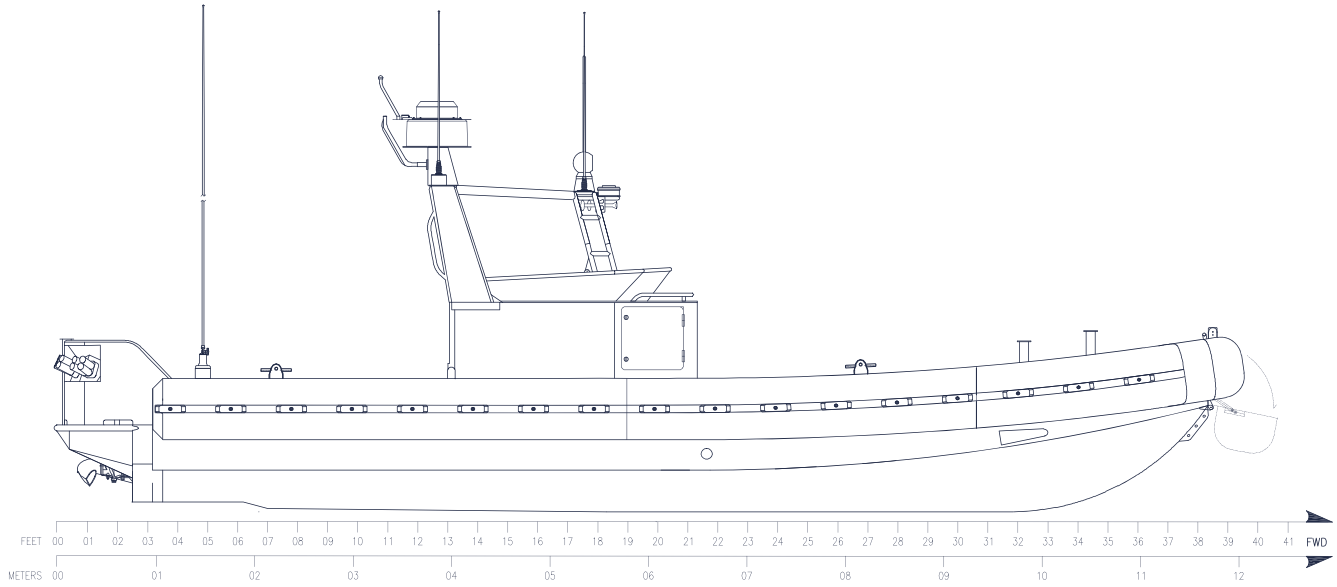

Length Overall (LOA) (feet) .....**39'-6"**  
 Length Overall (meters)..... **12.0**  
 Beam Overall (BOA) (feet) ..... **10'-2"**  
 Beam Overall (meters)..... **3.1**  
 Deadrise at Transom (degrees) .....**18**  
 Draft (static) (inches) ..... **24"**  
 Draft (static) (meters).....**0.61**  
 Max HP .....**1,500**

Top Speed (knots) .....**39+**  
 Max Range (NM) ..... **.250 @ 35 knots**  
 Fuel Cap (gal) ..... **300**  
 Seated Positions.....**2**  
 Dry Weight: vessel, no engines, no fuel,  
 no options, no liquids, no people, no cargo  
 (approximate) (lbs) .....**13,990**  
 Operational Load (lbs) ..... **22,500**

Height on trailer - Road Transport (feet) **13'-3"**  
 Length on trailer - Road Transport  
 (feet) .....**45'-5"**  
 Weight on Trailer (lbs) ..... **22,951**

*\*All specs, features and GAs shown are  
 subject to change*

## **HULL & DECK**

- 1/4" - 5086 bottom plate
- Reinforced, double keel beaching plate
- Six (6) fully welded performance lifting strakes
- Self-draining decks with four (4) scupper drains
- Flush, aft deck and insulated engine compartment
- Integrated aluminum weld-in deck pads to allow for tripod mount: centerline, fore and aft
- Sacrificial hull anode(s)

## **SUPER STRUCTURE**

- 60" side console with wind deflector
- Five individual weapons mount stations for heavy machine guns
- All outside lockers have fabricated aluminum access doors with venting designed to reduce water intrusion
- Forward cabin bow rails
- Swing down radar arch
- Dual, fabricated engine compartment hatches with stainless steel latches
- Drop bow door

## **SEATING, SEAT STORAGE & UPHOLSTERY**

- Dual console seating bolsters with flip-up seat bases that double as engine compartment air intake boxes
- Custom retractable/removable bimini over coxswain, flat with stainless steel frame

## **COLLAR SYSTEM**

- Patented 100% foam SAFE XDR-1 Extreme Duty Reinforced collar system in OD green
- Collar system easily removeable for aircraft or road transport

## **COATINGS, COVERINGS & LETTERING**

- Non-skid decks and gunnels
- Black rubberized dash skid
- Black mesh snap covers on interior storage box openings
- Rubberized deck matting on interior walking surfaces

## **TOWING, LIFTING & ATTACHMENT POINTS**

- Six (6), 10" cast aluminum weld-on cleats
- Custom fabricated weld-on pick eyes with stainless steel inserts
- Weld-on bow eye with triple stainless steel inserts
- Weld-on transom tie downs
- Aft tow post with single stainless steel cross pin

## **ELECTRICAL SYSTEM & POWER GENERATION**

- House battery system 24VDC
- Switch panel with marine-grade switches

## **LIGHTING**

- LED navigation lights (running and anchor)
- Independently controlled dimmable LED walkway lights
- Red/white dome lighting in helm area

## **ELECTRONICS, NAVIGATION & COMMUNICATION**

- Navigation horn

## **SAFETY, RESCUE & DIVING EQUIPMENT**

- Three (3) fire extinguishers
- Fabricated aluminium life ring mount
- Engine compartment fire suppression system
- Three (3) 2000 GPH bilge pumps - two (2) in engine space and one (1) in tank space

## **FUEL SYSTEM**

- 300-gallon fuel tank with a formed bottom (1/4" - 5086)
- Independent fuel stripping port



**SAFE RIVERINE PATROL BOAT**  
VISUAL REFERENCE + OPTIONAL EQUIPMENT

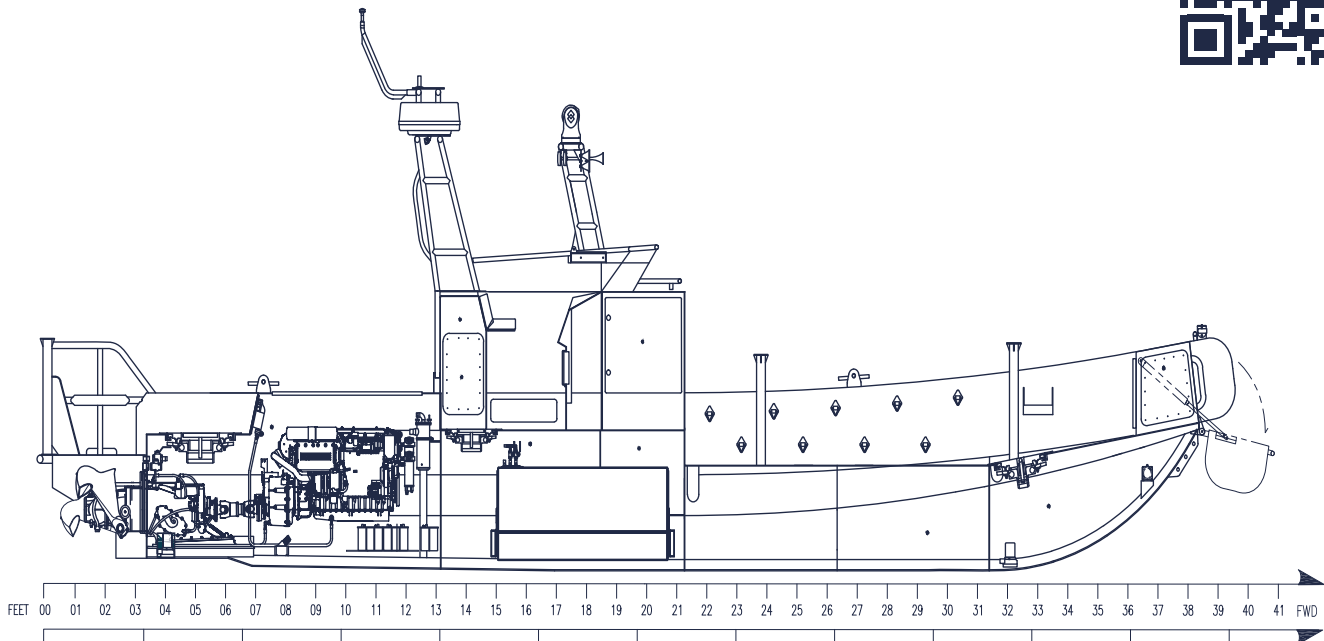

**PROPULSION**

- Engines (diesel)/Jets
- Engine(s) Rigging

**CONFIGURATION OPTIONS**

- Bow Cover
- Sheer Deck
- Personnel Recovery Cut-Outs (collar)
- Remotely Actuated Drop Bow
- Remotely Actuated Drop Transom
- Aft Bimini Top
- Reinforced Push Knees
- Locker System(s)
- SAFE XDR-2 Upgrade (lines & D-rings)
- Topside Paint
- Bottom Paint
- Tow Line Storage Spool/Cover/Line
- Davit/Electric Winch
- Self- Righting Upgrade

**ELECTRONICS/LIGHTING**

- Navigation Package(s)
- Side Scan Sonar
- Thermal/Low Light Camera Systems
- Loudhailer
- AIS
- Satellite Weather Receiver/Overlay
- VHF/UHF Radios
- Military Radio Systems
- Wired/Wireless Intercom System
- EPIRB
- Law Enforcement Lighting Strobes/Bars (blue/red/amber)
- Searchlights
- Upgraded Flood Lights
- Underwater Dive Lights
- Laptop Mounting/Docking station(s)
- Customer Furnished Equipment (CFE) Installation

**OUTFIT**

- Safety Kit
- Docking Kit
- Anchor Kit
- Personnel Flotation Device(s) (PFD)

**TRAILERING**

- Trailer with Bow Ladder

**DOCUMENTATION**

- Wire Label Package/Diagram(s)
- Drawing Package(s)
- Operator/Repair Manual(s)

**MISCELLANEOUS**

- Dive Ladder(s)
- Dive Tank Storage/holders
- Dive Light Mast
- Dive Staging Area
- Tow Light Mast
- Gun Locks/Locker(s)
- Fresh/Raw Water Washdown

*\*All specifications and standard features are subject to change. Not all options are available on all models. Please contact SAFE Sales Department for details.*