

SAFE 3812

FULL CABIN

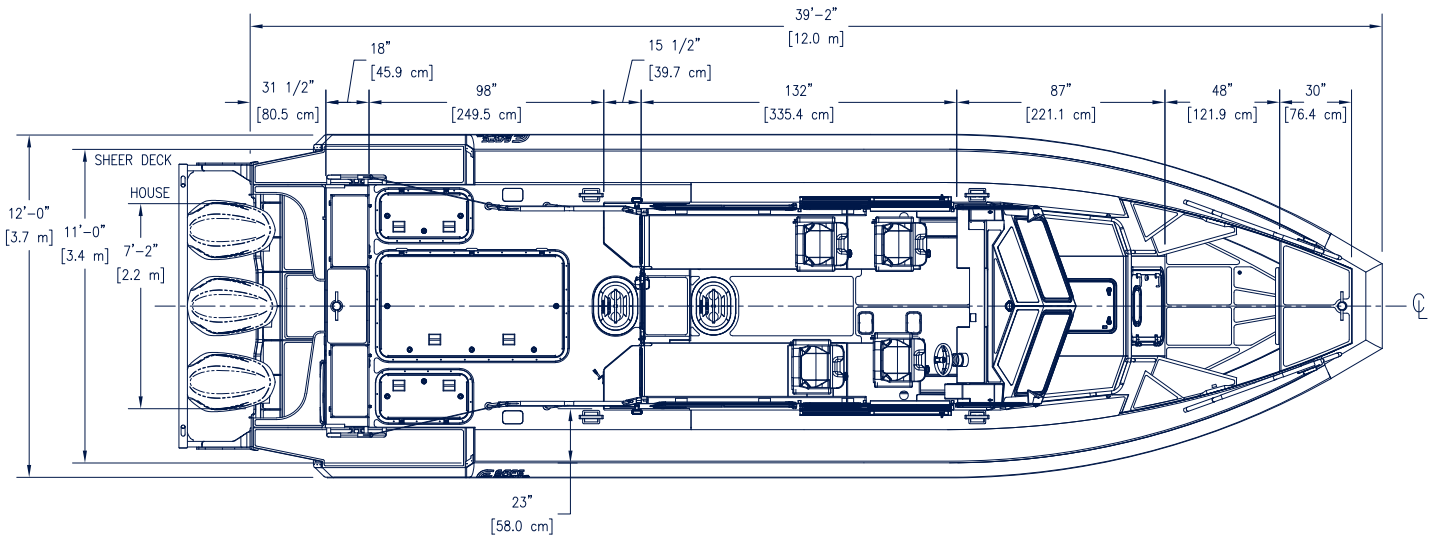

SAFE 3812 FULL CABIN
VISUAL REFERENCE + SPECIFICATIONS

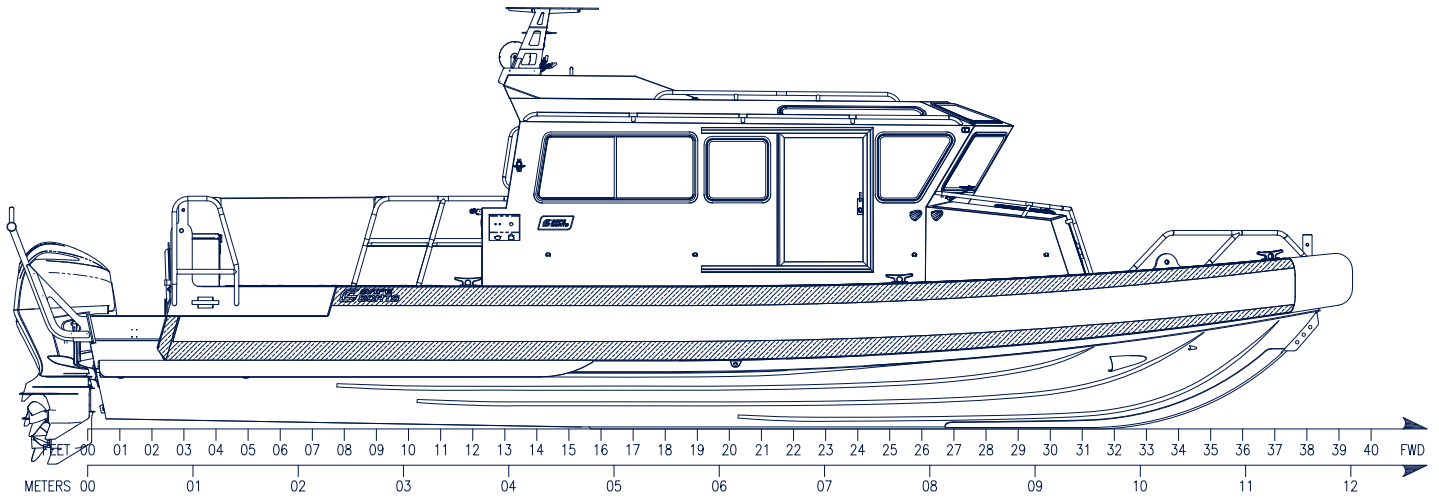

Length Overall (LOA) (feet) **39'-2"**
 Length Overall (meters)..... **12**
 Beam Overall (BOA) (feet) **10'**
 Beam Overall (meters)..... **3.1**
 Deadrise at Transom (degrees)..... **22**
 Draft (engine trimmed up) (inches)..... **26"**
 Max HP **1,600**
 Top Speed (knots) **60**

Max Range (NM) **300 with 10% reserve**
 Fuel Cap (gal) **400**
 Seated Positions..... **14**
 Light Ship: dry weight, weight of heaviest engines (lbs)..... **17,500**
 Operational Load (lbs)..... **19,940**
 Maximum payload: includes personnel, gear, and other customer-specific equipment.
 Does not include fuel (lbs) **4,000**

Height on trailer - Road Transport (feet) **13'-6"**
 Length on trailer - Road Transport (feet) **51'**
 Weight on Trailer (lbs) **24,440**

**All specs, features and GAs shown are subject to change*

HULL & DECK

- 5/16" - 5086 bottom plate
- Reinforced keel beaching plate
- Stepped transom with speed shoe in bottom plate
- Performance wings below collars for increased lift and stabilization while maneuvering
- Fully welded performance lifting strakes
- Self-bailing decks with high-volume scupper drains
- Forward cockpit with self-draining decks
- Bow storage/anchor locker with aft-facing door
- Dual aft rigging locker system with topside access
- Transom inspection hatch
- Sacrificial hull anode(s)

SUPER STRUCTURE

- Three weather-tight doors in main cabin
- Weather-tight, hinged cuddy access hatch
- Four (4) aft-sliding, weather-tight windows, two (2) port and two (2) starboard
- Cuddy with bench seating
- Overhead cuddy ceiling hatch
- Overhead spotter windows (tinted)
- Tempered glass used in all windows
- Safety hand/grab rail system
- Swing down radar pod

CONSOLE & DASH

- Starboard side helm
- OHIP - Over Head Instrument Panel

COLLAR SYSTEM

- Patented 100% foam SAFE XDR-1 Extreme Duty Reinforced collar system with black rubstrake
- Available collar colors include: black, blue, gray, orange, green, red

COATINGS, COVERINGS & LETTERING

- Marine-grade carpet and insulation
- Upholstered headliner
- Black mesh snap covers on interior storage box openings

TOWING, LIFTING & ATTACHMENT POINTS

- Eight (8), 10" cast aluminum weld-on cleats
- Custom fabricated weld-on pick eyes with stainless steel inserts
- Weld-on bow eye with triple stainless steel inserts
- Weld-on transom tie downs
- Fore and aft tow posts with single stainless steel cross pin
- Motor guard/tow line guide

ELECTRICAL SYSTEM & POWER GENERATION

- House battery system 12VDC - one (1) marine-grade battery with switch
- Backlit switch panel with marine-grade switches
- Five (5) 12VDC power receptacles - one (1) on gauge pod, two (2) on dash and two (2) on arch
- Self-parking, intermittent windshield wiper system with washer

LIGHTING

- LED navigation lights (running and anchor)
- Independently controlled interior/exterior dimmable LED walkway lights
- Three (3) red/white dome lights - two (2) in cabin, one (1) in cuddy

ELECTRONICS, NAVIGATION & COMMUNICATION

- Navigation horn

CREW COMFORT

- Two (2) ventilation fans

SAFETY, RESCUE & DIVING EQUIPMENT

- Three (3) fire extinguishers
- Life ring mount
- Cabin dewatering pump, 1100 GPH
- 1100 GPH bilge pump in outboard bracket
- CO detector(s) mounted in cabin
- Telescoping swim ladder mounted on outboard bracket

FUEL SYSTEM

- 400-gallon fuel tank with a formed bottom (1/4" - 5086)
- EPA-compliant fill and vent system with integrated check-valves, refueling vapors through carbon canister



SAFE 3812 FULL CABIN
VISUAL REFERENCE + OPTIONAL EQUIPMENT

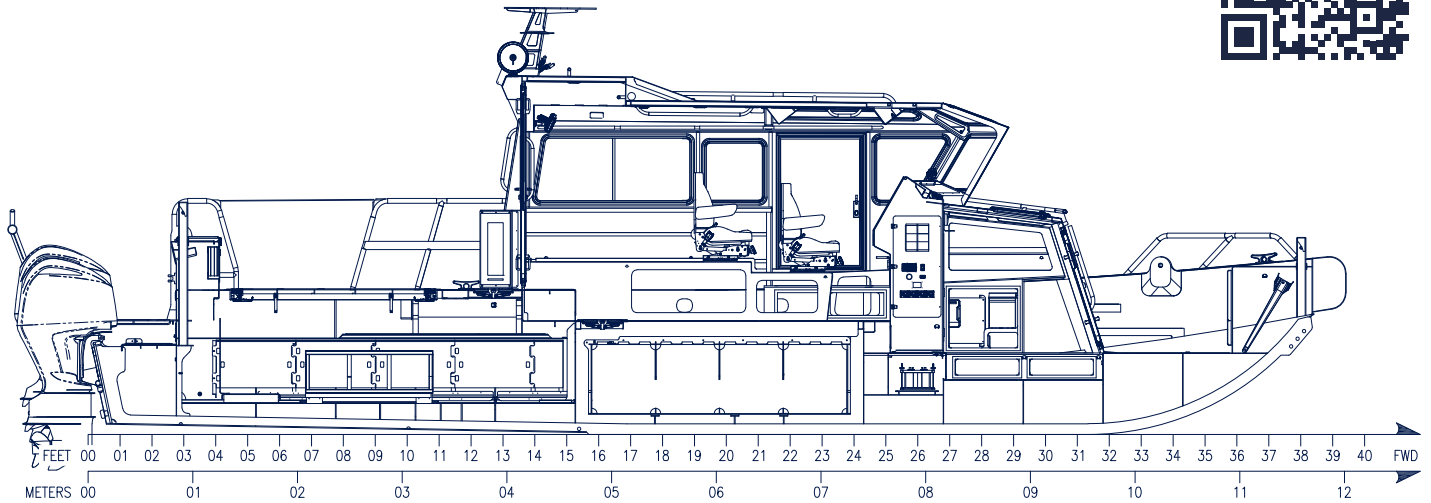

PROPULSION

- Engines
- Engine(s) Rigging
- Power Assist Steering Upgrade

CONFIGURATION OPTIONS

- Bow Cover
- Sheer Deck
- Personnel Recovery Cut-Outs (collar)
- Electronically Actuated Drop Bow
- Aft Bimini Top
- Reinforced Push Knees
- Locker System(s)
- Additional Aft Shock Mitigating Crew Seats
- Upgraded Premium Shock Mitigating Crew Seats
- SAFE XDR-2 Upgrade (lines & D-rings)
- Topside/Cabin Paint
- Bottom Paint
- Tow Line Storage Spool/Cover/Line
- Forward V-Birth Locker Bulkhead
- Sliding Cuddy Privacy Door/Privacy Curtain
- Interior Cabin Workstations
- Davit/Electric Winch
- Engine Guard/Tow Line Guide (standard on some models)
- Tow Post(s) (standard on some models)

ELECTRONICS/LIGHTING

- Navigation Package(s)
- Side Scan Sonar
- Thermal/Low Light Camera Systems
- Loudhailer
- AIS
- Satellite Weather Receiver/Overlay
- VHF/UHF
- Wired/Wireless Intercom System
- EPIRB
- Chemical Biological Radiological Nuclear Detection Equipment (CBRNE)
- Law Enforcement Lighting Strobes/Bars (blue/red/amber)
- Searchlights
- Upgraded LED Flood Lights
- Underwater Dive Lights
- Laptop Mounting/Docking Station(s)
- Customer Furnished Equipment (CFE) Installation

CREW COMFORT

- Generator
- Extreme Weather Generator Upgrade
- Air Conditioning
- Diesel Heater
- Shore Power
- Galley
- Head
- Fresh/Raw Water Washdown

OUTFIT

- Safety Kit
- Docking Kit
- Anchor Kit
- Personnel Flotation Device(s) (PFD)

TRAILERING

- Trailer with Bow Ladder
- Rolling Ship Yard Cradle

DOCUMENTATION

- Wire Label Package/Diagram(s)
- Drawing Package(s)
- Operator/Repair Manual(s)

MISCELLANEOUS

- Dive Ladder(s)
- Dive Tank Storage/Holders
- Dive Light Mast
- Tow Light Mast
- Gun Locks/Locker(s)
- Fire Fighting Pump/Engine Systems

**All specifications and standard features are subject to change. Not all options are available on all models. Please contact SAFE Sales Department for details.*