

INBOARD PLAN VIEW

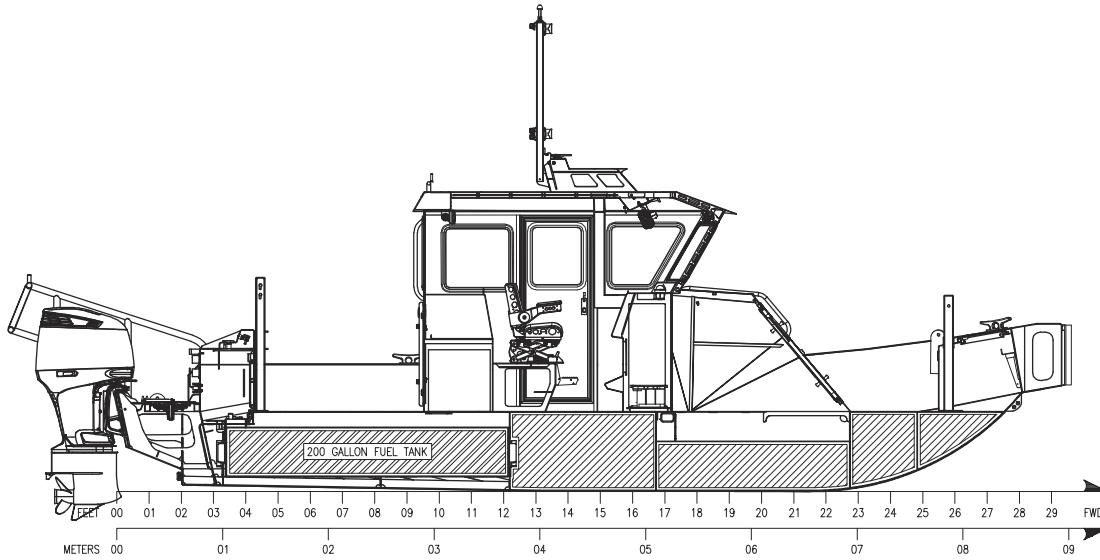

INBOARD PROFILE

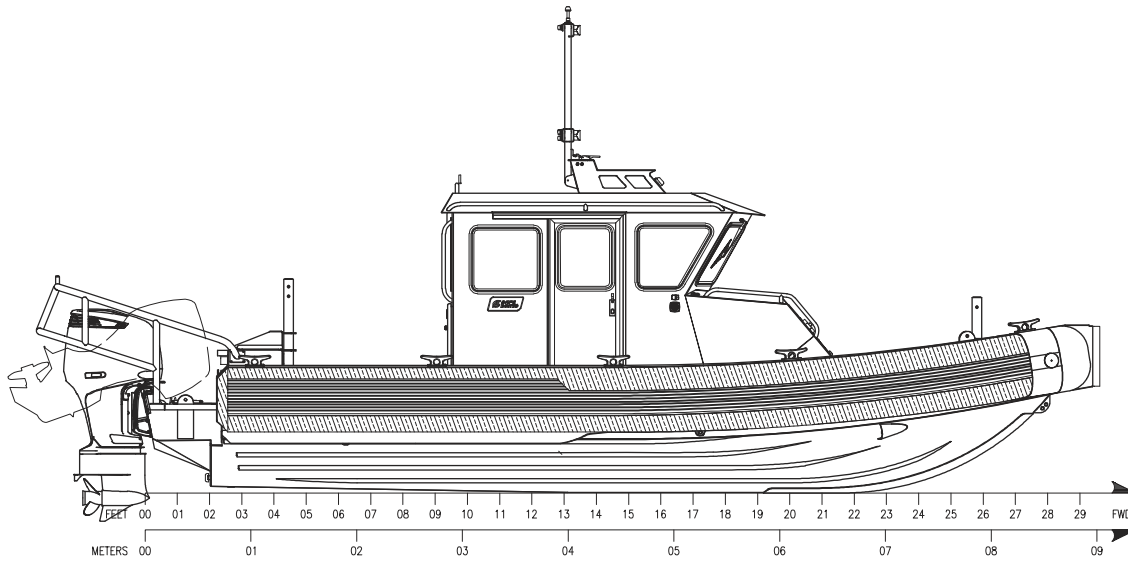

OUTBOARD PROFILE

SPECIFICATIONS

|                   |                          |
|-------------------|--------------------------|
| LOA               | 29'-4" [8.9]             |
| BEAM              | 10' [3.1]                |
| HEIGHT ON TRAILER | 12' [3.6]                |
| DEADRISE          | 25'                      |
| FUEL              | 200 GALLONS [757 LITERS] |
| MAX HP            | 600 [441.3 kW]           |

\*SHOWN WITH OPTIONAL ENGINES. SPECIFICATIONS ARE APPROXIMATES ONLY AND SUBJECT TO CHANGE.\*

THIS DOCUMENT DISCLOSES SUBJECT MATTER IN WHICH SAFE BOATS INTL., LLC. HAS PROPRIETARY RIGHTS. THE INFORMATION AND DESIGN DISCLOSED HEREIN WERE ORIGINATED BY AND ARE THE PROPERTY OF SAFE BOATS INTL., LLC. NEITHER RECEIPT NOR POSSESSION THEREOF CONFERS ANY RIGHT TO REPRODUCE, COPY, OR DISCLOSE THE DOCUMENT, ANY PART THEREOF, ANY INFORMATION CONTAINED THEREIN OR TO CONSTRUCT PRODUCTS FROM IT.

**SAFE BOATS**

GENERAL ARRANGEMENTS

|                        |                       |       |        |
|------------------------|-----------------------|-------|--------|
| SAFE BOATS DRAWING NO. | 329 - SAFE 29 TOW-WAC | REV   | -      |
| SCALE:                 |                       | SHEET | 1 OF 1 |